

SH3300

Glass louvre system

for maximizing air circulation 24h a day whilst providing a safe environment.



System Identity

A glass louvre system that offers comfort, design and performance in ventilation, lighting and sun protection, suitable for commercial and residential buildings.

The "Jalousie" system is very popular in the tropics, where the blinds fulfil a vital role in regulating indoor temperatures.

As in all Aluminco systems, only the highest materials and accessories are used to minimise maintenance and ensure long-term performance.

Features & Benefits

- Glass movable louvers 6 mm thickness with rotation centers of 120 mm or 145 mm.
- Possibility of fixed glass on the top, can meet different heights.
- Possibility of glass louvers or blind profile.
- Perimeter water tightness assured by high quality seals.
- Handled by a special cremone, which performs motion 0°- 90°- 180° and fins respectively 0°- 45°- 90°.
- Mounting capability of supporting frame profiles at the top and bottom of the structure.
- Mounted independently or in collaboration with opening - sliding frames.
- Perimeter accepts joint covers for improved aesthetics.

Plastic cap permitting harmonious axial rotation up to 90° of the sash.

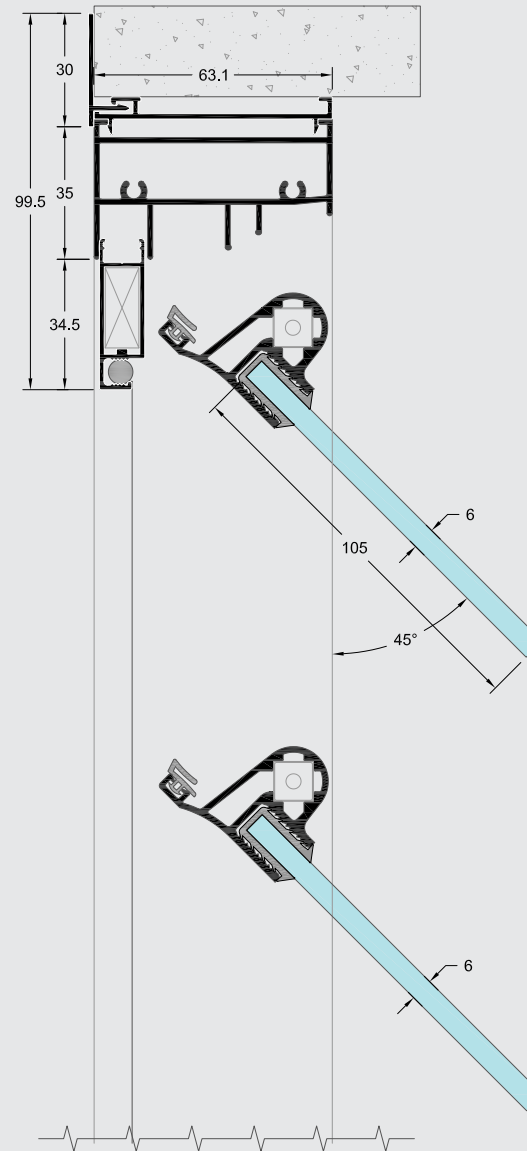
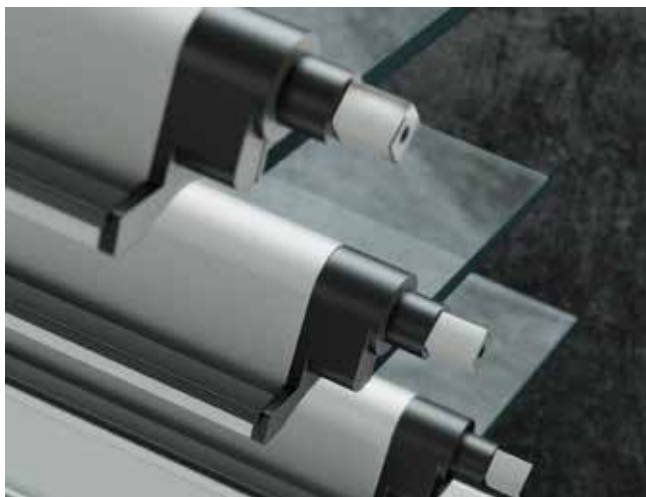

FRAME DIMENSIONS

MIN FRAME FACE HEIGHT mm	37
FACE LOUVER HEIGHT mm	40
MAX NUMBER OF LOUVERS PER CONSTRUCTION	10
GLASS THICKNESS mm	6

CONSTRUCTION DIMENSIONS

WIDTH mm	300-1400
HEIGHT mm	300-2300*
MAX. CONSTRUCTION DIMENSIONS mm	1000x2300*

* With partition to 1200 mm